

WALTER CLAMP-FIT PROPELLER SHAFT COUPLINGS

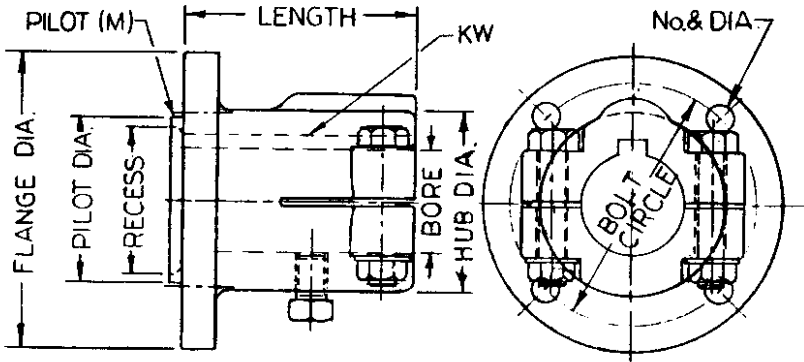

<u>BORES</u>	<u>KEYWAY</u>	<u>PILOT RINGS</u>
1/2 - 11/16"	1/8 x 1/16"	Used to mate two
3/4 - 3/16"	3/16 x 3/32"	"SAE" flanges
7/8 - 1-3/16"	1/4 x 1/8"	(changes one female
1-1/4 - 1-7/16"	5/16 x 5/32"	pilot to male pilot)
1-1/2 - 1-11/16"	3/8 x 3/16"	
1-3/4 - 1-15/16"	7/16 x 7/32"	SAE #2 \$29.80
2 - 2-3/16"	1/2 x 1/4"	SAE #3 36.60
2-1/4 - 2-7/16"	9/16 x 9/32"	SAE #4 47.25
2-1/2 - 2-15/16"	5/8 x 5/16"	4-3/4" 72.00
3 - 3-7/16"	3/4 x 3/8"	(for 9"AA & 9"BA)
3-1/2 - 3-15/16"	7/8 x 7/16"	
4 - 4-7/16"	1 x 1/2"	

Custom flanges can be manufactured on request -- please call for details. Prices are subject to change; invoice price will be price prevailing at time of shipment.

FLANGE DIA/ PART #	BOLT DIA AND (#)	BOLT CIR- CLE	PILOT DIA. MALE (M) OR FEMALE (F)	TOTAL LENGTH	HUB DIA.	CAST PILOT HOLE	BORE RANGE	RECESS	TRANS- MISSION	NOTES
4"AS	3/8" (4)	3-1/4"	2 x 3/32"M	2"	2"	5/8"	3/4 - 1-1/4"	1-3/4 x 3/16"	P	--
4"BS	3/8" (4)	3-1/4"	2-1/2 x 3/32"M	2"	2"	5/8"	3/4 - 1-1/4"	2-1/16 x 3/16"	W,H,Z	--
4"CS	3/8" (4)	3-1/4"	2-5/8 x 3/32"M	2"	2"	5/8"	3/4 - 1-1/4"	2-1/4 x 3/16"	P	--
4"YS	10mm (4)	78mm	50mm x 3/32"M	2"	2"	5/8"	3/4 - 1-1/4"	1-7/16 x 5/8"	Y	--
4"A	3/8" (4)	3-1/4"	2 x 3/32"M	3-1/4"	2-1/2"	3/4"	1 - 1-1/2"	1-3/4 x 3/16"	P	--
4"B	3/8" (4)	3-1/4"	2-1/2 x 3/32"M	3-1/4"	2-1/2"	3/4"	1 - 1-1/2"	2-1/16 x 3/16"	W,H,Z	--
4"C	3/8" (4)	3-1/4"	2-5/8 x 3/32"M	3-1/4"	2-1/2"	3/4"	1 - 1-1/2"	2-1/4 x 3/16"	P	--
4-3/4"A (SAE2)	7/16" (6)	3-7/8"	2-1/2 x 3/16"F	3-5/16"	2-1/2"	3/4"	1 - 1-1/2"	--	T,C,Z	6
4-3/4"B (SAE2)	7/16" (6)	3-7/8"	2-1/2 x 3/16"F	3-3/4"	3"	1-1/4"	1-5/8 - 2"	--	T,C,Z	6
5"A	7/16" (4)	4-1/4"	2-1/2 x 3/32"M	3-5/16"	2-1/2"	3/4"	1 - 1-1/2"	2-1/16 x 11/32"	W,H,Z	1,6
5"B	3/8" (4)	4-1/8"	2-3/4 x 3/32"M	3-5/16"	2-1/2"	3/4"	1 - 1-1/2"	2-7/16 x 7/16"	P	--
5"C	7/16" (4)	4-1/4"	2-1/2 x 3/32"M	3-3/4"	3"	1-1/4"	1-5/8 - 2"	2-1/16 x 11/32"	W,H,Z	1,6
5"D	3/8" (4)	4-1/8"	2-3/4 x 3/32"M	3-3/4"	3"	1-1/4"	1-5/8 - 2"	2-7/16 x 7/16"	P	--
5"YA	7/16" (4)	4-1/4"	2-1/2 x 3/32"M	3-5/16"	2-1/2"	3/4"	1 - 1-1/2"	2-1/4 x 9/16"	Y	--
5-3/4"A (SAE3)	1/2" (6)	4-3/4"	3 x 3/16"F	4"	3"	7/8"	1-1/4 - 1-3/4"	--	W,T,C,A,Z	2
5-3/4"B (SAE3)	1/2" (6)	4-3/4"	3 x 3/16"F	4-1/2"	3-5/8"	1-1/2"	2 - 2-1/4"	--	W.T.C.A.Z	2
7-1/4"A (SAE4)	5/8" (6)	6"	3-3/4 x 3/16"F	4-1/4"	3-1/4"	1"	1-1/4 - 1-3/4"	--	T,C,A	3
7-1/4"B (SAE4)	5/8" (6)	6"	3-3/4 x 3/16"F	5"	4-3/8"	1-3/4"	2 - 2-3/4"	--	T,C,A	3
7-1/4"BC	5/8" (8)	6"	3-3/4 x 3/16"F	5"	4-3/8"	1-3/4"	2 - 2-3/4"	--	Z	--
8"AA	5/8" (8)	171mm	140mm x 9/32"F	5"	4-7/8"	1-1/4"	1-1/2 - 2-3/4"	--	Z	--
8"AB	18mm (10)	170mm	140mm x 9/32"F	5"	4-7/8"	1-1/4"	1-1/2 - 2-3/4"	--	Z	--
9"AA	3/4" (6)	7-1/2"	4-3/4 x 9/32"F	5"	4-7/8"	1-1/4"	1-1/2 - 2-3/4"	--	T	--
9"AB	3/4" (8)	7-1/2"	6 x 7/32"F	5"	4-7/8"	1-1/4"	1-1/2 - 2-3/4"	--	T,A	4
9"AC	5/8" (8)	7-3/4"	5-1/8 x 7/32"F	5"	4-7/8"	1-1/4"	1-1/2 - 2-3/4"	4 x 1-1/4"	C	--
9"AD	5/8" (8)	196mm	140mm x 9/32"F	5"	4-7/8"	1-1/4"	1-1/2 - 2-3/4"	--	Z	--
9"BA	3/4" (6)	7-1/2"	4-3/4 x 9/32"F	6-1/4"	5-7/8"	2-1/2"	3 - 4"	--	T	5
9"BB	3/4" (8)	7-1/2"	6 x 7/32"F	6-1/4"	5-7/8"	2-1/2"	3 - 4"	--	T,A	4,5
9"BC	5/8" (8)	7-3/4"	5-1/8 x 7/32"F	6-1/4"	5-7/8"	2-1/2"	3 - 4"	4 x 1-1/4"	C	5
10-1/2"A	1" (8)	8-3/4"	5 x 9/32"F	6"	4-5/8"	1-3/4"	2 - 2-3/4"	--	T	--
10-1/2"B	1" (8)	8-3/4"	5 x 9/32"F	6-1/2"	5-7/8"	2-1/4"	3 - 4"	--	T	5

TRANSMISSION KEY:

A = ALLISON C = CAPITOL H = HURTH P = PARAGON T = TWIN DISC
Y = YANMAR W = WARNER Z = ZF

- NOTES:** 1 = For Hurth HBW-400 & HBW-600, 8 holes required 4 = For Twin Disc, drill holes for 7/8" bolts
2 = For Twin Disc & ZF, drill holes for 5/8" bolts 5 = Couplings with 4" bore have 1 x 3/8" keyway, use 1 x 7/8" key
3 = For Twin Disc, drill holes for 3/4" bolts 6 = For ZF, drill holes for 12mm bolts

