

WALTER KEEL COOLERS

STANDARD KEEL COOLER

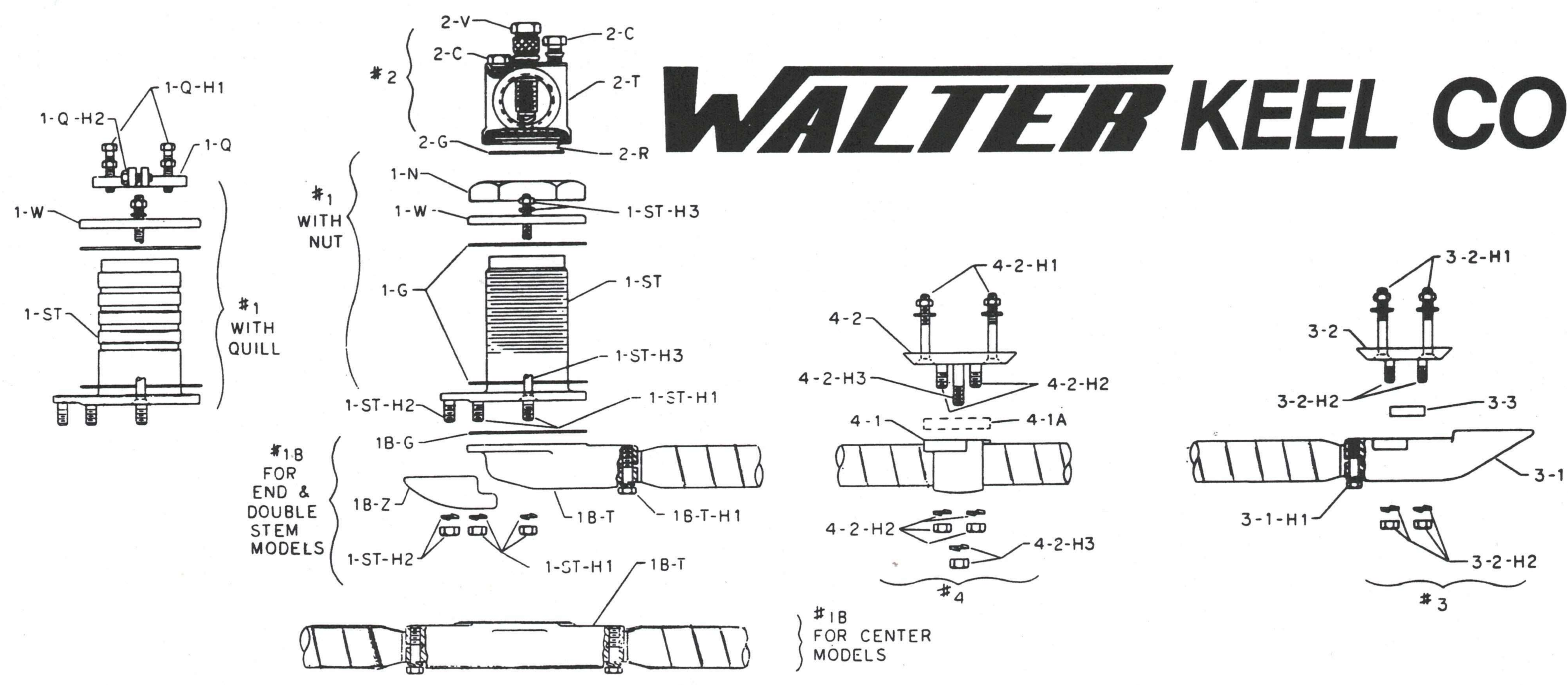

KEEL COOLER WITH INSULATING MATERIAL (FOR STEEL HULLS)

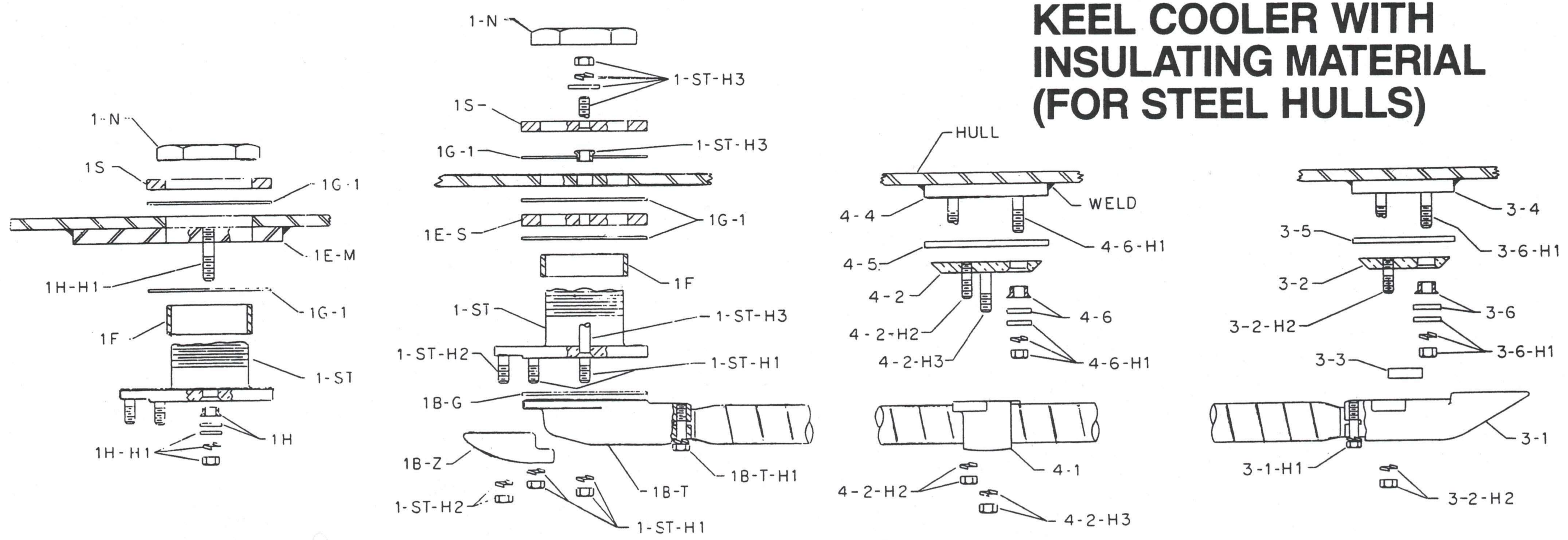

1	STEM ASSEMBLY (COMPLETE)
1-ST	STEM
1-ST-H1	STUD, NUT, & LW
1-ST-H2	STUD, NUT, & LW
1-ST-H3	FH SCREW, NUT, & LW
1-Q	QUILL
1-Q-H1	BOLT & NUT
1-Q-H2	HEX HEAD CAP SCREW
** 1-W	WASHER
* 1W-R	WASHER
1-N	NUT
** 1-G	HULL GASKET (EACH)
* 1G-1	HULL GASKET (EACH)
* 1S	INSIDE SPACER
* 1E-M	MOUNTING PLATE, STEM ASSEM.
* 1E-S	OUTSIDE SPACER
* 1F	COLLAR
* 1H	INSUL. SLEEVE & WASHER
* 1H-H1	STUD, NUT, WASHER, & LW
1B	TUBE PLATE ASSEMBLY (COMPLETE)
1B-T	TUBE PLATE
1B-T-H1	CLAMPING SCREW & LW
1B-Z	ZINC, TUBE PLATE
1B-G	TUBE PLATE GASKET
2	TEE CAP ASSEMBLY (COMPLETE)
2-T	TEE CAP
2-V	TEMP. ADJ. SCREW, LN, & O-RING
2-R	O-RING, TEE CAP
2-C	CAP SCREW W / NYL. WASHER
2-G	TEE CAP GASKET

3	RETURN FITTING ASSEMBLY (COMPLETE)
3-1	RETURN FITTING
3-1-H1	CLAMPING SCREW & LW
3-2	RETURN MOUNTING PLATE
** 3-2-H1	FH SCREW, NUT, & WASHER
3-2-H2	STUD, NUT, & LW
3-3	ZINC, RETURN FITTING
* 3-4	MOUNTING PLATE, RETURN FITTING
* 3-5	INSULATING PLATE
* 3-6	INSUL SLEEVE & WASHER
* 3-6-H1	STUD, NUT, WASHER, & LW
4	TUBE CLAMP ASSEMBLY (COMPLETE)
4-1	TUBE CLAMP
*** 4-1A	CLAMP SPACER
4-2	CLAMP MOUNTING PLATE
** 4-2-H1	FH SCREW, NUT, & LW
4-2-H2	STUD, NUT, & LW
4-2-H3	STUD, NUT, & LW
* 4-4	MOUNTING PLATE, TUBE CLAMP ASSEM.
* 4-5	INSULATING PLATE
* 4-6	INSUL. SLEEVE & WASHER
* 4-6-H1	STUD, NUT, WASHER, & LW

NOTES: * - Used only with insulating material , unless noted
 ** - Not used with insulating material, unless noted
 *** - Used only with double stack keel coolers
 + - One used with & without insulating material